

BOX BASE ASSEMBLY

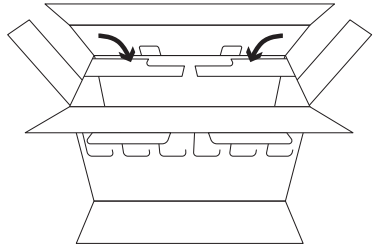

① Turn box upside down & fold in 1st small flaps

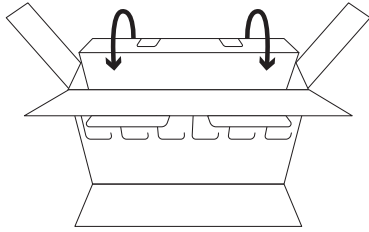

② Fold over 1st large flap

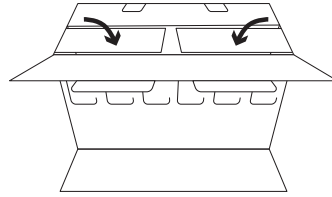

③ Fold in 2nd small flaps

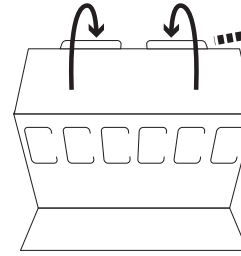

④ Fold over 2ND large flap

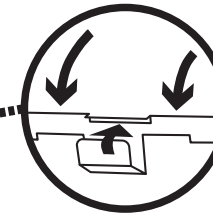

Lock flaps down

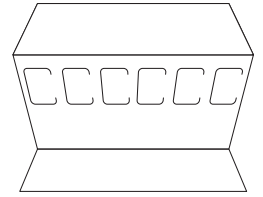

⑤ Finished base

BOTTLE DIVIDER & BOX LID ASSEMBLY

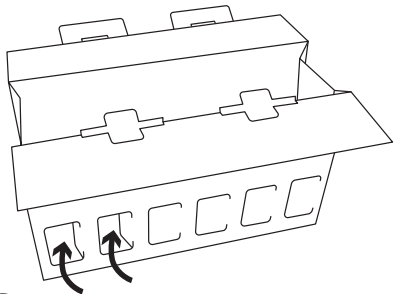

① Push in windows/bottle dividers

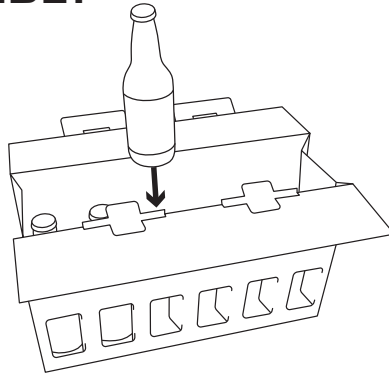

② Place bottles between dividers & rotate so labels are visible

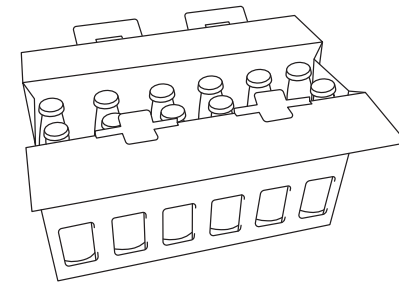

③ Box full of bottles

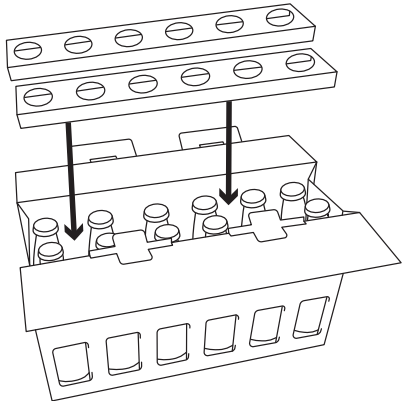

④ Insert bottle neck dividers

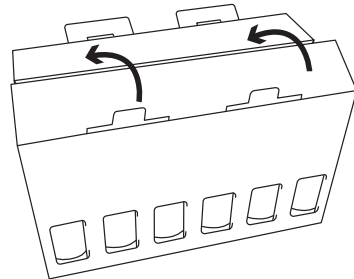

⑤ Fold over front flap

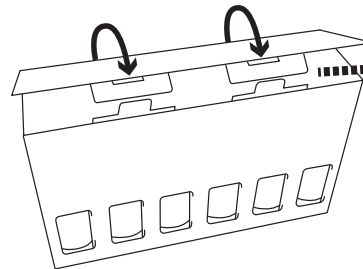

⑥ Fold over back flap

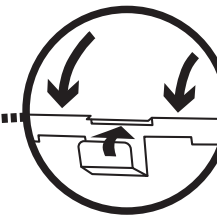

Lock flaps down

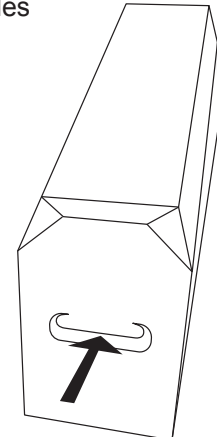

⑦ Push in carry handle flaps